



# Model MKH-3

## Automatic end load cartoner



The MKH-3 series is a fully automatic cartoner system designed to end-load a variety of products into a boxes.

The MKH-3 cartoner automatically opening sleeves style cartons for product loading, The MKH-3 is extremely easy and fast carton size change (with in 5 – 10 Min.)

The MKH-3 have a special and simple design for over load feeding system.

The MKH-3 have a feeding control on the feeders, while no product, no carton.

The MKH-3 machine is easy clean and access to all parts.

Designed for quiet low maintenance operation.

**LEAD also offers a wide variety of loader, accumulation, and infeed sections to solve your toughest case packaging needs.**

## Special application upon request

# Model MKH-3

## Automatic end load cartoner

# MKH-3

### Features

- AC variable speed drive.
- Automatic advance horizontal magazine for ease of loading.
- Digital indicators and calibrated scales.
- Venturi vacuum source.
- Automatic opening sleeves style cartons for product loading.
- Stainless steel construction.
- 6" touch screen with diagnostic alarms.
- 24 VDC control voltage.
- Variable magazine length.
- Omron PLC controller.
- Over load system on the feeding system.
- Hot melt glue system.
- CE standard.

### Options

- Servo drive.
- Tuck-in style.
- Tuck-in + glue style.
- Carton shape – triangle, and other as request.
- Date coding.
- Right Left version available.
- Leaflet system.
- Barcode, farma code.

### Application

Bags, toys, tooth brushes, tubes, medicals, panty shields, bottles, jars, cans, wafers, etc.

### Specifications

**Production speed:** Up to 50 carton per minute.  
**Final speed:** dependent of the product, product orientation and length.

#### Box size range

**Minimum:** 100 L. x 20W. x 20H.  
**Maximum:** 330 L. x 220W. x 110H.

Special application upon request

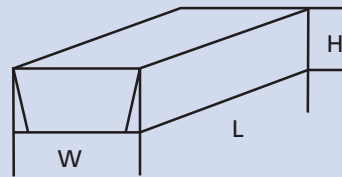

#### Electrical requirements

**Input Power:** 200/380 Volt, 3 Phase, 60 Hz  
2.5KW  
Other required is available  
**Control Circuit:** 24 VDC  
**Net weight:** 850 Kg

#### Air requirements

**Operating Pressure:** 89 psi (6 atm)  
**Line Pressure:** 104 psi (7 atm)  
**Air Use Per Min.:** 200 liters  
**Hot Melt Air Pressure:** 20 - 60 psi (1.4 - 4 atm)

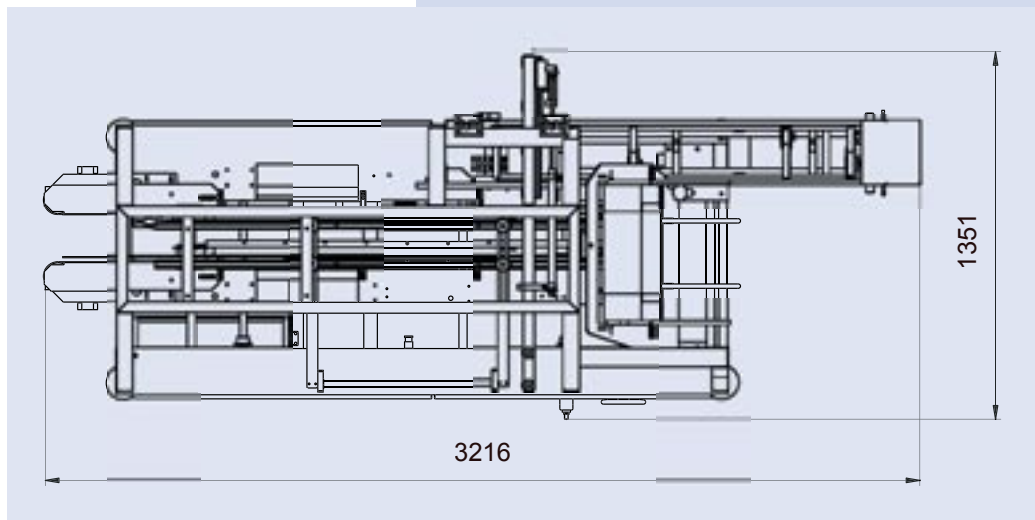

LEAD TECHNOLOGY LTD.

61 Habrosh St., Neve Yamin, Israel TEL 972-9-7664519 FAX 972-9-7664403 E-MAIL sales@lead.co.il

www.lead.co.il