

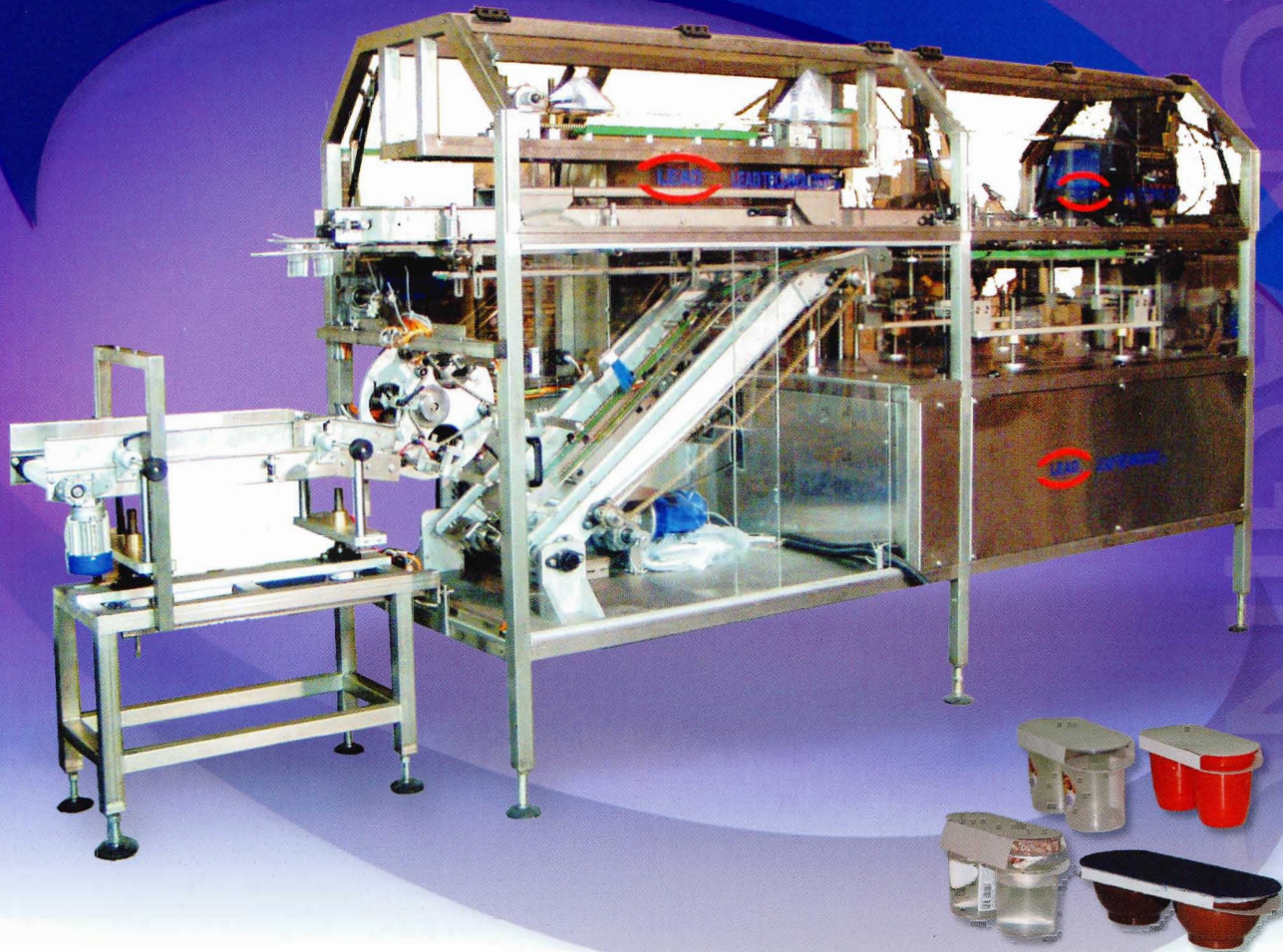

LEAD

Model MP-20

Partial Wrap Around Cartoning Machine



The MP-20 series is a fully automatic Cartoner system designed to partial wrap around multi pack product.

The MP-20 series using a three head rotary feeder cartons with the flow of the machine.

Magazine up to 1000 cartons with Auto' feeding system.

The MP-20 is extremely easy and fast carton size change (with in 15 Min.)

The MP-20 has a feeding control by two belt drive or wheels that feed the product.

The MP-20 machine is easy cleaning, washable and access to all parts.

Designed for quiet low maintenance operatio.

LEAD also offers a wide variety of loader, accumulation, and infeed sections to solve your toughest case packaging needs. ■

Model MP-20

Wrap Around Cartoning Machine

Features

- Simple and economic partial wrap around for multi pack product.
- AC variable speed drive.
- Automatic advance horizontal magazine for ease of loading.
- Digital indicators and calibrated scales.
- Venturi vacuum source.
- Stainless steel construction.
- Sealing on top.
- 6" touch screen with diagnostic alarms.
- 24 VDC control voltage.
- Variable magazine length.
- Omron PLC controller.
- Over load system on the feeding system.
- Hot melt glue system.

Options

- Servo drive.
- Top cup.
- Date coding.
- Right Left version available.

Specifications

Production speed: Up to 130 wrap per minute
Final speed: dependent of product and product orientation.

Wrap size range: Versatile, upon request.

Electrical requirements

Input Power: 200/380 Volt, 3 Phase, 60 Hz
2.5KW
Others required is available
Control Circuit: 24 VDC
Net weight: 1100 Kg.

Air requirements

Operating Pressure: 80 psi (5.4 atm)
Line Pressure: 90 psi (6.1 atm)
Air Use Per Cycle: 5 liters free air per cycle
Hot Melt Air Pressure: 20 - 60 psi (1.4 - 4 atm)

Application

Jars, Cans, Plastic Pots, etc...

Any configuration can be considered:

- 1 row.
- 2, 3, 4, 5, 6 Pc.
- 1,2 layers.

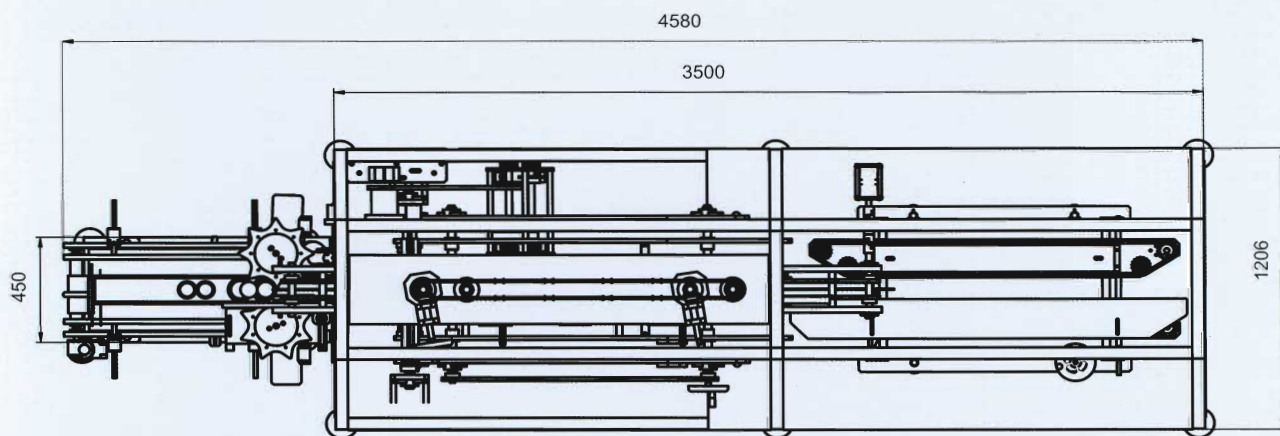

LEAD TECHNOLOGY LTD.

11000010